

PRORIL

60 Hz

GOFLOW Series, these non-clog pumps can handle solids up to 37 mm in diameter without clogging. These pumps are equipped with a semi-open channel impeller, a wide channel for the pump to pass solids from inflow to discharge with minimal blockage.

Sewage Pump

GOFLOW 315

Non-clog Pump



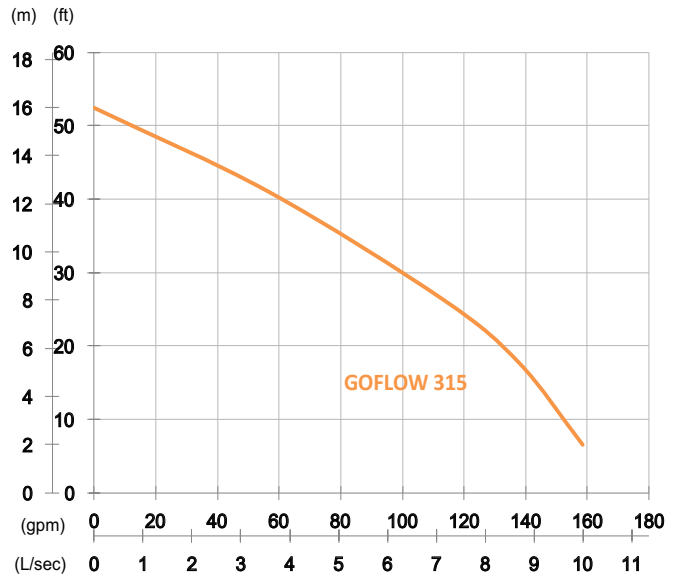

Shaft Speed : 3450 rpm

Outlet : 80mm, 3in

OUTPUT	HEAD	FLOW
1.5 kW	Rated : 8m, 26ft	Rated : 7.2 L/s, 114 gpm
2 HP	Max : 16m, 52ft	Max : 10 L/s, 159 gpm
Solid Passage : 25mm, 1in		

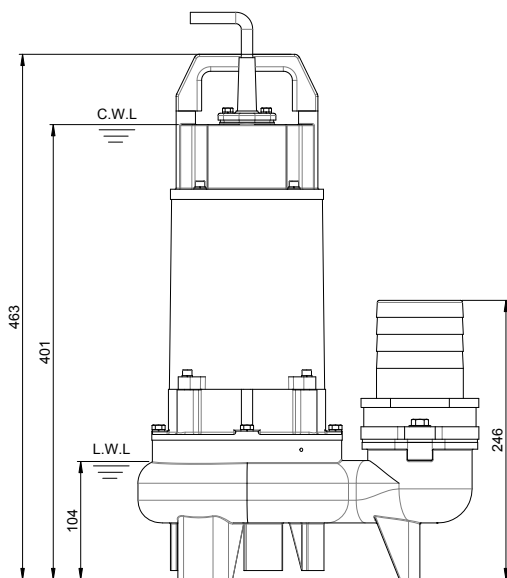
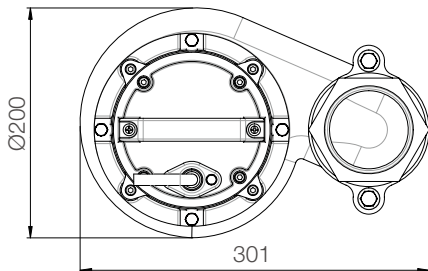

unit : mm

Weight : 27kg / 60 lbs

Pump Type		Electric Submersible Pumps
		1-Phase, 3-Phase
Motor	Type	Induction Motor
	Poles	2 Pole
	Insulation	Class F
	Protector	Circle Thermal Protector
	Starter	1-Phase · Capacitor-Run, 3-Phase · D.O.L.
Lubricant		Food Grade (ISO VG32)
Impeller Type		Semi-Open Channel
Shaft Seal		Double Mechanical Seal
		Silicon Carbide VS Ceramic / Carbon
Bearings		C3 Shielded ball bearings
Cable		PVC (OSA Certified) / H07RN-F
		6m (20ft) or longer upon request.
Materials	Pump Casing	Gray Iron
	Impeller	Gray Iron
	Motor Frame	Gray Iron
	Motor Shaft	Stainless Steel
Max. Liquid Temperature		40°C (104°F)
Max. Submersion Depth		20m (66ft)
pH Range		pH 5 - pH 8
Guide Rail		GRL-03F